



Control the Air in your System

LKUV-2 Air-Relief Valve

Application

LKUV-2 is a reliable, automatic air-relief valve which is installed vertically on the top of a pipeline or before the inlet for a pump, where the removal of air is required. This valve is designed for operation with liquids having a specific gravity of 1.0 or higher. Below are two examples of using the LKUV-2.

Example 1:

Bleeding of a pipe line where an air pocket has formed on account of the installation. In this case the valve is installed at the top of the pipe.

Example 2:

Bleeding of a pipe on the suction side of a pump. The suction side is bled automatically, before the pump starts, establishing a vacuum. Binding of air to the product will be prevented, and hence subsequent cavitation. In this case the valve is installed in front of the pump, on top of the inlet pipe.

Working principle

LKUV-2 is a double-seated valve with a freely moving plastic ball. The ball, which is lighter than water, closes against the upper or lower seat, depending on the pressure conditions.



Fig. 1. LKUV-2, Air-relief valve

Situation 1

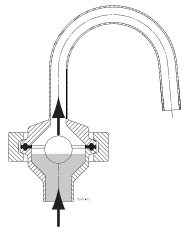

Pressure conditions

Pressure, air or product, or air/product.

Effect

The ball is lifted from the lower seat. The air can escape until the product lifts the ball against the upper seat, closing the valve.

Situation 2

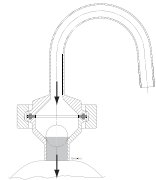

Pressure conditions

Vacuum, air or product, or air/ product.

Effect

The ball moves against the lower seat, closing the valve, whether it contains air or product, or air/product.

Note! Important for correct function:

- Product density higher than the ball density.
- Vertical installation.
- Pure products.

Standard design

The valve body is in two parts and assembled by means of a clamp.
The lower valve body has a welding stub.

Parts List

1. Upper valve body.
2. Seal ring.
3. Valve body.
4. Ball.

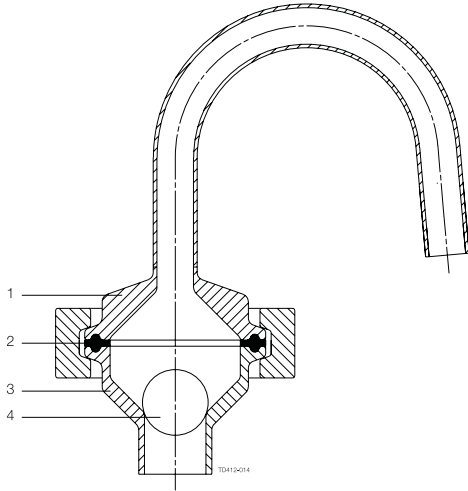

Fig. 2. Parts Lists drawing

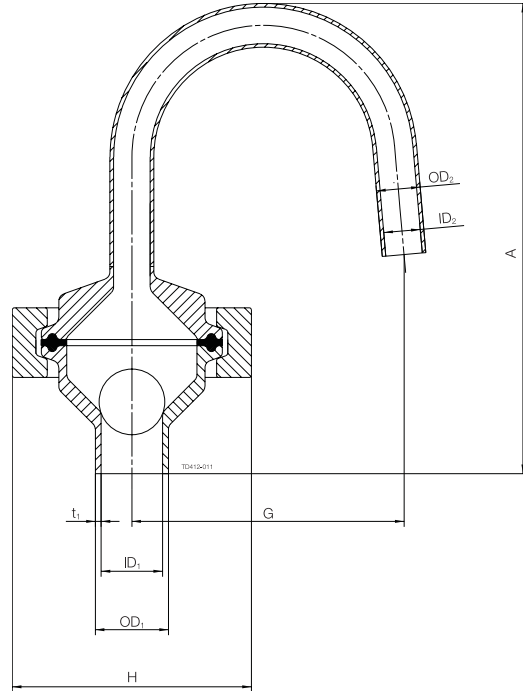

Fig. 3. Dimensions

Dimensions

Dimension	(mm)	(inch)
A	128,7	5.07
OD1	20	0.79
ID1	16,8	0.66
T1	1,6	0.06
OD2	12	0.47
ID2	10	0.39
G	74,5	2.93
H	58,5	2.57
Weight	(kg)	(lb)
	0,6	1.32

Technical data

Max. product pressure:1000 kPa/145 psi (10 bar).
 Max. temperature:90°C/194°F (because of the plastic ball).
 Density of ball:0.906 kg/dm³.

Options:

Alternative elastomers:

- NBR (Buna N)
- FPM (SFY)

Materials

Steel parts:Stainless steel AISI 304.
 Ball:Polypropylene.
 Seal ring:EPDM.
 Finish:Bright.

ESE00379ENUS 0705

The information contained herein is correct at the time of issue, but may be subject to change without prior notice.

How to contact Alfa Laval

Contact details for all countries are continually updated on our website. Please visit www.alfalaval.com to access the information direct.