



# The Premium Pump

## LKH Centrifugal Pump

### Applications

The LKH pump is a highly efficient and economical centrifugal pump, which meets the requirements of sanitary and gentle product treatment and chemical resistance. LKH is available in eleven sizes, LKH-5, -10, -15, -20, -25, -35, -40, -45, -50, -60, -70 and -90

### Standard design

The LKH pump consists of a standard motor, stub shaft, mechanical compression coupling (LKH-5 with set screws), adaptor, back plate, impeller, impeller screw, pump casing and shaft seal. (LKH-5 has clamp connection between pump casing and back plate). The LKH pump is designed for CIP with emphasis on large internal radii and cleanable seals.

### Shaft seals

The LKH pump is equipped with either an external single or a flushed shaft seal. Both have stationary seal rings in acid-resistant steel AISI 329 with sealing surface in silicon carbide and rotating seal rings in carbon. The secondary seal of the flushed seal is a long lasting lip seal. The pump may also be equipped with a double mechanical shaft seal.

### Materials

Product wetted steel parts: . . . . . Acid-resistant steel AISI 316L and AISI 329L  
Other steel parts: . . . . . Stainless steel AISI 304  
Finish: . . . . . Polished  $\leq 32Ra$ . and 3A approved  
Product wetted seals: . . . . . EPDM rubber.

### Technical data

Max. inlet pressure (dynamic) . . . . .  
LKH-5 . . . . . 87 PSI  
LKH-10 - LKH-60 . . . . . 145 PSI  
LKH-70 - LKH-90 . . . . . 72.52 PSI  
LKH-90 . . . . . 72.52 PSI  
Temperature range . . . . . 14°F to +284° F (EPDM)  
Noise level (at 3.3 ft.): . . . . . 60 - 85 dB (A).

### Flushed shaft seal (LKH-5 to LKH-90):

Water pressure inlet: . . . . . Max. 14.5 PSI.  
Water consumption: . . . . . 4-8 usgph

### Double mechanical shaft seal:

Water pressure inlet, LKH-5 to -60: . . . . . Max. 72.5 PSI.  
Water pressure inlet, LKH-70 and -90: . . . . . Max. 43.5 PSI.  
Water consumption: . . . . . 4-8 usgph

### Connections for FSS and DMSS

R 1/8" (BSP) external thread.



LKH-10

### Motor

Standard C-faced, foot mounted motor according to NEMA standard. 3500 RPM or 1750 RPM. Standard efficiency, Class F. Note frame size per horsepower.

LKH-90 4 poles = 1500/1800 RPM at 72.52/145 PSI.

### Voltage and frequency

3 phase, 60 HZ, 230/460V standard. Other voltages and frequencies available upon request.

## Dimensions (in)

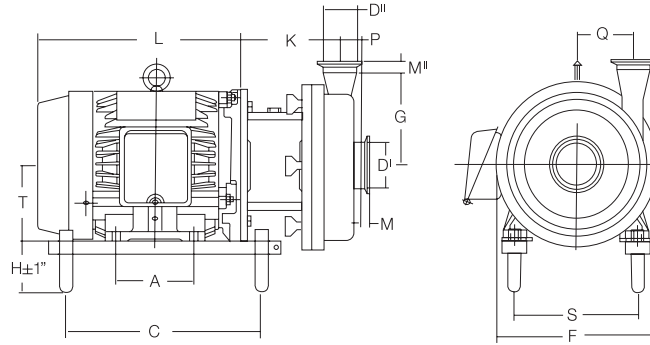

### LKH-5

Size	Motor			
	1 Hp (56C)	1.5 Hp (143TC)	2 Hp (145TC)	3 HP (182TC)
A	4.00	4.00	5.00	4.50
C	9.53	9.53	9.53	12.60
F	7.87	7.87	7.87	7.87
G	6.22	6.22	6.22	6.22
H	3.50	3.50	3.50	3.50
K	5.31	5.31	5.31	5.90
L	16.53	16.53	17.52	18.01
P	0.866	0.866	0.866	0.866
Q	2.80	2.80	2.80	2.80
S	5.50	5.50	5.50	7.50
T	3.50	3.50	3.50	4.50
Approximate weight (lbs.)	69.00	79.90	79.90	99.90

### LKH-10

Size	Motor						
	1 Hp (143TC)	1.5 Hp (143TC)	2 Hp (145TC)	3 HP (182TC)	5 Hp (184TC)	7.5 Hp (213TC)	10 Hp (215TC)
A	4.00	4.00	5.00	4.50	5.50	5.50	7.00
C	9.53	9.53	9.53	12.60	12.60	14.17	14.17
F	9.72	9.72	9.72	9.72	9.72	9.72	9.72
G	5.59	5.59	5.59	5.59	5.59	5.59	5.59
H	3.50	3.50	3.50	3.50	3.50	3.50	3.50
K	5.35	5.35	5.35	5.87	5.87	5.87	5.87
L	16.91	16.91	18.22	19.41	19.69	23.20	24.74
P	0.91	0.91	0.91	0.91	0.91	0.91	0.91
Q	3.43	3.43	3.43	3.43	3.43	3.43	3.43
S	5.51	5.51	5.51	7.48	7.48	8.50	8.50
T	3.50	3.50	3.50	4.50	4.50	5.25	5.25
Approximate weight (lbs.)	81.00	89.00	91.00	111.00	128.00	179.00	204.00

### LKH-15

Size	Motor							
	1 Hp (143TC)	1.5 Hp (143TC)	2 Hp (145TC)	3 Hp (182TC)	5 Hp (184TC)	7.5 Hp (213TC)	10 Hp (215TC)	15 Hp (254TC)
A	4.00	4.00	5.00	4.50	5.50	5.50	7.00	7.00
C	9.53	9.53	9.53	12.60	12.60	14.17	14.17	19.02
F	9.72	9.72	9.72	9.72	9.72	9.72	9.72	9.72
G	6.54	6.54	6.54	6.54	6.54	6.54	6.54	6.54
H	3.50	3.50	3.50	3.50	3.50	3.50	3.50	3.50
K	5.98	5.98	5.98	6.50	6.50	7.24	7.24	8.25
L	18.33	18.33	19.32	20.33	21.38	24.62	25.03	29.76
P	1.70	1.70	1.70	1.70	1.70	1.70	1.70	1.70
Q	2.61	2.61	2.61	2.61	2.61	2.61	2.61	2.61
S	5.51	5.51	5.51	7.48	7.48	8.50	8.50	8.50
T	3.50	3.50	3.50	4.50	4.50	5.25	5.25	5.25
Approximate weight (lbs.)	88.00	96.00	98.00	118.00	135.00	186.00	211.00	304.00

## Dimensions (in)

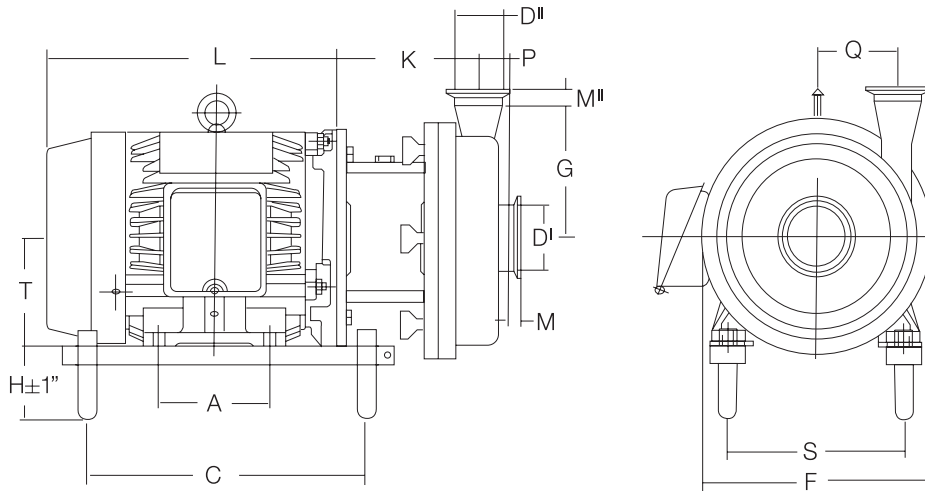

### LKH-20

Size	Motor							
	1 Hp (143TC)	1.5 Hp (143TC)	2 Hp (145TC)	3 HP (182TC)	5 Hp (184TC)	7.5 Hp (213TC)	10 Hp (215TC)	15 Hp (254TC)
A	4.00	4.00	5.00	4.50	5.50	5.50	7.00	8.25
C	9.53	9.53	9.53	12.60	12.60	14.17	14.17	19.02
F	9.96	9.96	9.96	9.96	9.96	9.96	9.96	9.96
G	7.09	7.09	7.09	7.09	7.09	7.09	7.09	7.09
H	3.50	3.50	3.50	3.50	3.50	3.50	3.50	3.50
K	5.67	5.67	5.67	6.18	6.18	6.93	6.93	7.95
L	17.38	17.38	18.28	19.37	20.42	23.67	25.21	28.82
P	1.06	1.06	1.06	1.06	1.06	1.06	1.06	1.06
Q	3.47	3.47	3.47	3.47	3.47	3.47	3.47	3.47
S	5.51	5.51	5.51	7.48	7.48	8.50	8.50	10.00
T	3.50	3.50	3.50	4.50	4.50	5.25	5.25	5.25
Approximate weight (lbs.)	85.00	93.00	95.00	115.00	132.00	183.00	208.00	301.00

### LKH-25

Size	Motor										
	1 Hp (143TC)	1.5 Hp (143TC)	2 Hp (145TC)	3 HP (182TC)	5 Hp (184TC)	7.5 Hp (213TC)	10 Hp (215TC)	15 Hp (254TC)	20 Hp (256TC)	25 Hp (284TSC)	30 Hp (286TSC)
A	4.00	5.00	5.00	4.50	5.50	5.50	7.00	8.25	10.00	9.50	11.00
C	9.53	9.53	9.53	12.60	12.60	14.17	14.17	19.02	19.02	20.00	20.00
F	11.93	11.93	11.93	11.93	11.93	11.93	11.93	11.93	11.93	11.93	11.93
G	7.60	7.60	7.60	7.60	7.60	7.60	7.60	7.60	7.60	7.60	7.60
H	3.50	3.50	3.50	3.50	3.50	3.50	3.50	3.50	3.50	3.50	3.50
K	5.98	5.98	5.98	6.50	6.50	7.24	7.24	8.07	8.07	8.07	8.07
L	17.91	17.91	18.90	19.91	20.96	24.20	25.74	29.16	30.91	32.91	34.41
P	1.28	1.28	1.28	1.28	1.28	1.28	1.28	1.28	1.28	1.28	1.28
Q	4.17	4.17	4.17	4.17	4.17	4.17	4.17	4.17	4.17	4.17	4.17
S	5.51	5.51	5.51	7.48	7.48	8.50	8.50	10.00	10.00	11.00	11.00
T	3.50	3.50	3.50	4.50	4.50	5.25	5.25	6.25	6.25	7.00	7.00
Approximate weight (lbs.)	95.00	103.00	105.00	125.00	142.00	193.00	218.00	311.00	361.00	442.00	473.00

**Dimensions (in)**

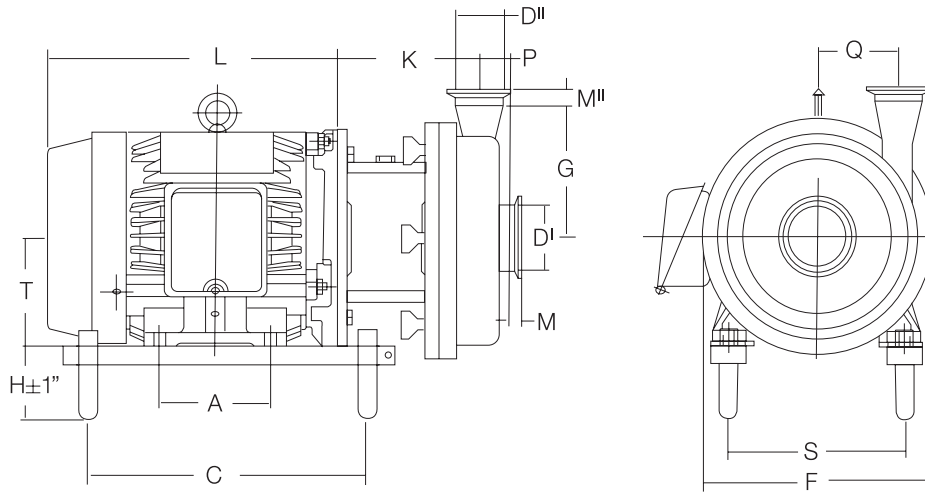

**LKH-35**

Size	Motor									
	1.5 Hp (143TC)	2 Hp (145TC)	3 HP (182TC)	5 Hp (184TC)	7.5 Hp (213TC)	10 Hp (215TC)	15 Hp (254TC)	20 Hp (256TC)	25 Hp (284TSC)	30 Hp (286TSC)
A	4.00	5.00	4.50	5.50	5.50	7.00	8.27	10.00	9.49	11.00
C	9.53	9.53	12.60	12.60	14.17	14.17	19.02	19.02	20.00	20.00
F	11.93	11.93	11.93	11.93	11.93	11.93	11.93	11.93	11.93	11.93
G	7.60	7.60	7.60	7.60	7.60	7.60	7.60	7.60	7.60	7.60
H	3.50	3.50	3.50	3.50	3.50	3.50	3.50	3.50	3.50	3.50
K	5.55	5.55	6.06	6.06	6.81	6.81	7.83	7.83	7.83	7.83
L	17.11	18.10	19.10	20.15	20.15	24.94	28.55	30.30	32.30	33.80
P	0.91	0.91	0.91	0.91	0.91	0.91	0.91	0.91	0.91	0.91
Q	4.68	4.68	4.68	4.68	4.68	4.68	4.68	4.68	4.68	4.68
S	5.51	5.51	7.48	7.48	8.50	8.50	10.00	11.00	11.00	11.00
T	3.50	3.50	4.50	4.50	5.25	5.25	6.25	6.25	7.00	7.00
Approximate weight (lbs.)	99.00	101.00	121.00	138.00	189.00	214.00	307.00	357.00	438.00	469.00

**LKH-40**

Size	Motor									
	1.5 Hp (143TC)	2 Hp (145TC)	3 HP (182TC)	5 Hp (184TC)	7.5 Hp (213TC)	10 Hp (215TC)	15 Hp (254TC)	20 Hp (256TC)	25 Hp (284TSC)	30 Hp (286TSC)
A	4.00	5.00	4.50	5.50	5.50	7.00	8.25	10.00	9.50	11.00
C	9.53	9.53	12.60	12.60	14.17	14.17	19.02	19.02	20.00	20.00
F	12.95	12.95	12.95	12.95	12.95	12.95	12.95	12.95	12.95	12.95
G	8.35	8.35	8.35	8.35	8.35	8.35	8.35	8.35	8.35	8.35
H	3.50	3.50	3.50	3.50	3.50	3.50	3.50	3.50	3.50	3.50
K	5.75	5.75	6.26	6.26	7.01	7.01	8.03	8.03	8.03	8.03
L	17.50	18.49	19.49	22.54	23.79	25.33	28.94	30.69	32.69	34.19
P	1.10	1.10	1.10	1.10	1.10	1.10	1.10	1.10	1.10	1.10
Q	4.96	4.96	4.96	4.96	4.96	4.96	4.96	4.96	4.96	4.96
S	5.51	5.51	7.48	7.48	8.50	8.50	10.00	10.00	11.00	11.00
T	3.50	3.50	4.50	4.50	5.25	5.25	6.25	6.25	7.00	7.00
Approximate weight (lbs.)	108.00	110.00	130.00	147.00	198.00	223.00	316.00	366.00	447.00	487.00

## Dimensions (in)

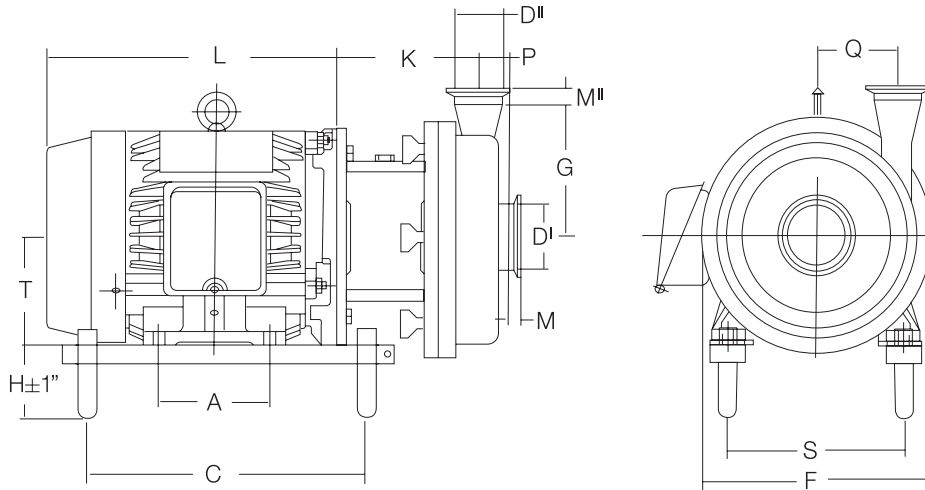

### LKH-45

Size	Motor									
	1.5 Hp (143TC)	2 Hp (145TC)	3 Hp (182TC)	5 Hp (184TC)	7.5 Hp (213TC)	10 Hp (215TC)	15 Hp (254TC)	20 Hp (256TC)	25 Hp (284TSC)	30 Hp (286TSC)
A	4.00	5.00	4.50	5.50	5.50	7.00	8.25	10.00	9.50	11.00
C	9.53	9.53	12.60	12.60	14.17	14.17	19.02	19.02	20.00	20.00
F	11.93	11.93	11.93	11.93	11.93	11.93	11.93	11.93	11.93	11.93
G	7.60	7.60	7.60	7.60	7.60	7.60	7.60	7.60	7.60	7.60
H	3.50	3.50	3.50	3.50	3.50	3.50	3.50	3.50	3.50	3.50
K	6.03	6.03	6.54	6.54	7.29	7.29	8.31	8.31	8.31	8.31
L	18.27	19.26	20.26	21.31	24.56	26.10	29.71	31.46	33.46	34.96
P	1.59	1.59	1.59	1.59	1.59	1.59	1.59	1.59	1.59	1.59
Q	3.83	3.83	3.83	3.83	3.83	3.83	3.83	3.83	3.83	3.83
S	5.51	5.51	7.48	7.48	8.50	8.50	10.00	10.00	11.00	11.00
T	3.50	3.50	4.50	4.50	5.25	5.25	6.25	6.25	7.00	7.00
Approximate Weight (lbs.)	105.00	107.00	127.00	144.00	195.00	220.00	313.00	363.00	444.00	475.00

### LKH-50

Size	Motor									
	1.5 Hp (143TC)	2 Hp (145TC)	3 Hp (182TC)	5 Hp (184TC)	7.5 Hp (213TC)	10 Hp (215TC)	15 Hp (254TC)	20 Hp (256TC)	25 Hp (284TSC)	30 Hp (286TSC)
A	4.00	5.00	4.50	5.50	5.50	7.00	8.25	10.00	9.50	11.00
C	9.53	9.53	12.60	12.60	14.17	14.17	19.02	19.02	20.00	20.00
F	12.95	12.95	12.95	12.95	12.95	12.95	12.95	12.95	12.95	12.95
G	8.07	8.07	8.07	8.07	8.07	8.07	8.07	8.07	8.07	8.07
H	3.50	3.50	3.50	3.50	3.50	3.50	3.50	3.50	3.50	3.50
K	5.91	5.91	6.42	6.42	7.17	7.17	8.27	8.27	8.27	8.27
L	17.98	18.97	19.97	21.02	24.27	26.06	29.50	31.25	33.25	34.75
P	1.42	1.42	1.42	1.42	1.42	1.42	1.42	1.42	1.42	1.42
Q	4.61	4.61	4.61	4.61	4.61	4.61	4.61	4.61	4.61	4.61
S	5.51	5.51	7.48	7.48	8.50	8.50	10.00	10.00	11.00	11.00
T	3.50	3.50	4.50	4.50	5.25	5.25	6.25	6.25	7.00	7.00
Approximate weight (lbs.)	108.00	110.00	130.00	147.00	198.00	223.00	316.00	366.00	447.00	487.00

## Dimensions (in)

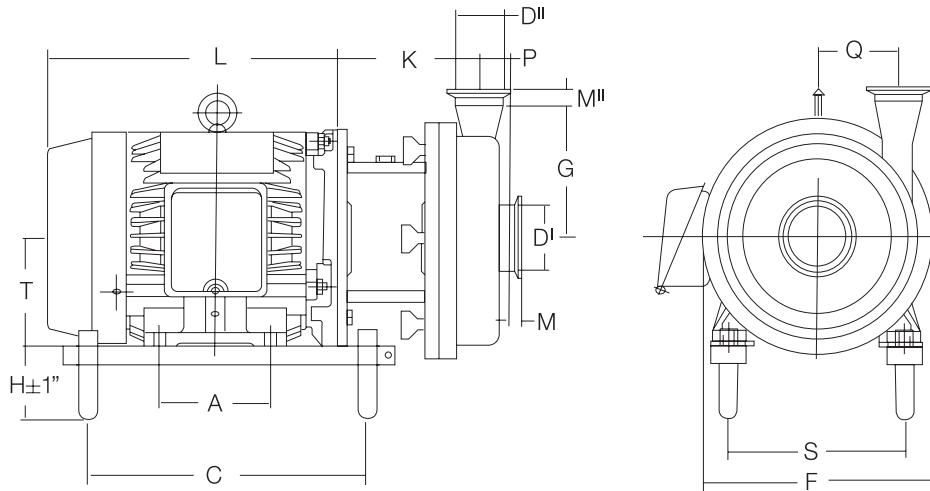

### LKH-60

Size	Motor									
	1.5 Hp (143TC)	2 Hp (145TC)	3 Hp (182TC)	5 Hp (184TC)	7.5 Hp (213TC)	10 Hp (215TC)	15 Hp (254TC)	20 Hp (256TC)	25 Hp (284TSC)	30 Hp (286TSC)
A	4.00	5.00	4.50	5.50	5.50	7.00	8.25	10.00	9.50	11.00
C	9.53	9.53	12.60	12.60	14.17	14.17	19.02	19.02	20.00	20.00
F	12.95	12.95	12.95	12.95	12.95	12.95	12.95	12.95	12.95	12.95
G	10.31	10.31	10.31	10.31	10.31	10.31	10.31	10.31	10.31	10.31
H	3.50	3.50	3.50	3.50	3.50	3.50	3.50	3.50	3.50	3.50
K	5.96	5.96	6.47	6.47	7.22	7.22	8.32	8.32	8.32	8.32
L (4 x 4)	19.05	20.04	21.04	22.09	25.34	26.88	30.57	32.32	34.32	35.82
L (6 x 4)	20.63	21.62	22.62	23.67	26.92	28.46	32.15	33.90	35.90	37.40
P (4 x 4)	2.44	2.44	2.44	2.44	2.44	2.44	2.44	2.44	2.44	2.44
P (6 x 4)	4.02	4.02	4.02	4.02	4.02	4.02	4.02	4.02	4.02	4.02
Q	4.02	4.02	4.02	4.02	4.02	4.02	4.02	4.02	4.02	4.02
S	5.51	5.51	7.48	7.48	8.50	8.50	10.00	10.00	11.00	11.00
T	3.50	3.50	4.50	4.50	5.25	5.25	6.25	6.25	7.00	7.00
Approximate weight (lbs.)	113.00	115.00	135.00	152.00	209.00	228.00	321.00	371.00	452.00	483.00

### LKH-70

Size	Motor								
	15 Hp (254TC)	20 Hp (256TC)	25 Hp (284TSC)	30 Hp (286TSC)	40 Hp (324TSC)	50 Hp (326TSC)	60 Hp (364TSC)	75 Hp (365TSC)	100 Hp (405TSC)
A	8.25	10.00	9.50	11.00	10.50	12.00	11.25	12.25	13.75
C	19.02	19.02	20.00	20.00	20.00	21.00	21.00	21.00	21.00
F	16.13	16.13	16.13	16.13	16.13	16.13	16.13	16.13	16.13
G	10.04	10.04	10.04	10.04	10.04	10.04	10.04	10.04	10.04
H	3.50	3.50	3.50	3.50	3.50	3.50	3.50	3.50	3.50
K	8.21	8.21	8.21	8.21	11.25	11.25	11.25	11.25	11.25
L (4 x 3)	29.52	31.27	33.27	34.77	37.21	38.70	40.31	41.31	47.83
P 4"	1.50	1.50	1.50	1.50	1.50	1.50	1.50	1.50	1.50
Q	5.79	5.79	5.79	5.79	5.79	5.79	5.79	5.79	5.79
S	10.00	10.00	11.00	11.00	12.50	12.50	14.00	14.00	16.00
T	6.25	6.25	7.00	7.00	8.00	8.00	9.00	9.00	10.00
Approximate weight (lbs.)	113.00	115.00	135.00	152.00	209.00	228.00	321.00	371.00	452.00

**Dimensions (in)**  
(900315/0)

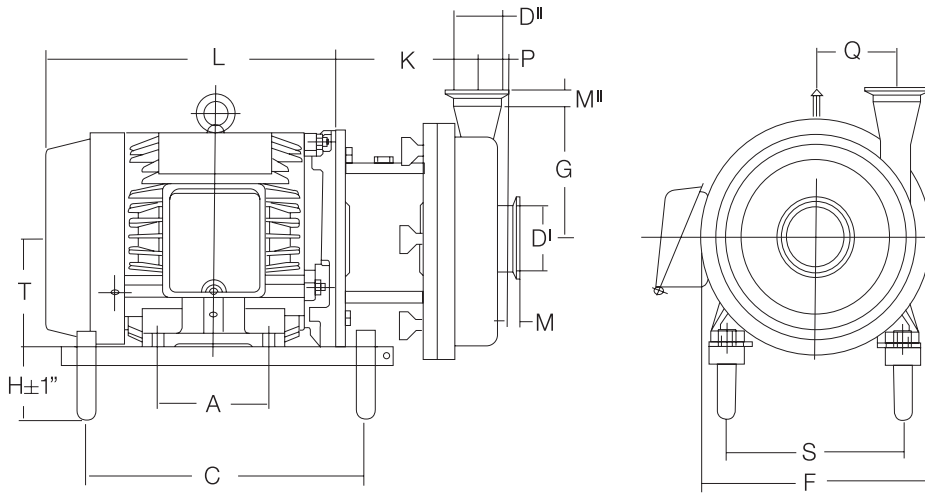

**LKH-90**

Size	Motor-Sterling					
	30Hp	40Hp	50Hp	60Hp	75Hp	100Hp
B	11.00	10.50	12.00	11.25	12.25	13.75
C	9.37	9.86	9.86	12.88	12.88	13.87
E	2.56	2.56	2.56	2.56	2.56	2.56
F	11.92	12.92	12.92	13.92	13.92	14.92
G	20.00	21.00	21.00	21.00	21.00	21.00
H	12.20	12.20	12.20	12.20	12.20	12.20
J	11.00	12.50	12.50	14.00	14.00	16.00
Q	15.37	15.87	15.87	16.50	16.50	17.49
R	9.84	9.84	9.84	9.84	9.84	9.84
S	24.02	24.10	26.32	26.92	27.90	33.35
T	7.00	8.00	8.00	9.00	9.00	10.00
U	8.38	8.79	8.79	9.79	9.79	10.79
Z	21.69	21.69	21.69	23.42	23.42	26.86
K	26.16	27.48	27.48	30.44	30.44	33.99
L	34.89	34.97	37.19	37.79	38.77	44.22
Weight (lbs)	939	974	1084	1236	1424	1497

## Technical Data Volumetric Flow

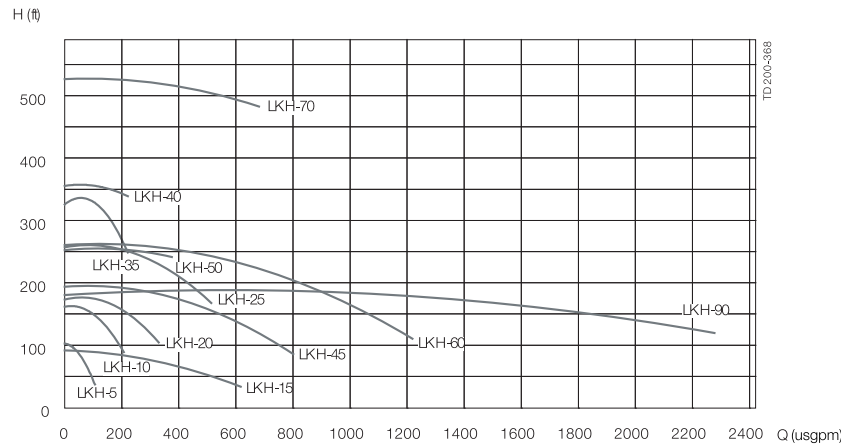

### Inlet/Outlet Connections - Tri-Clamp® (inches)

Refer to dimensional drawings

	LKH-5	LKH-10 LKH-20 LKH-35	LKH-25	LKH-40	LKH-15 LKH-45 LKH-50 LKH-70	LKH-60	LKH-60 LKH-70*	LKH-90
DI	2.00	2.50	3.00	3.00	4.00	4.00	6.00	6.00
DII	1.50	2.00	2.50	2.00	3.00	4.00	4.00	6.00
MI	1.13	1.13	1.13	1.13	1.13	1.13	1.50	1.5
MII	1.13	1.13	1.13	1.13	1.13	1.13	1.13	1.5

\* = LKH-60, -70 are with reducer on DI.

### Options Equipment

- Impeller with reduced diameter.
- Motor for other voltage and/or frequency.
- Motor enclosures: washdown, TEFC, explosion proof, inverter duty and others upon request.
- Inducer (only LKH-10 to -50)
- Flushed shaft seal.
- Double mechanical shaft seal.
- Counter flanges, seal rings and bolts for flanged connections (industrial version).
- Standard clearance is 0.02" (0.04" for LKH-70) and can be made up to 0.098").

### Material grades

- Surface roughness, product wetted parts: unpolished, 32Ra.
- Product wetted seals of Buna (NBR), Fluoroelastomer (FPM) or FEP.
- Rotating seal ring of silicon carbide.

### Ordering

Please state the following when ordering:

- Pump size.
- Version, sanitary or industrial.
- Connections.
- Seal and Elastomer Type
- Impeller diameter.
- Motor size.
- Voltage and frequency.
- Flow, pressure and temperature.
- Density and viscosity of the product.
- Options.

ESE00263ENUS 0705

The information contained herein is correct at the time of issue, but may be subject to change without prior notice.

### How to contact Alfa Laval

Contact details for all countries are continually updated on our website. Please visit [www.alfalaval.com](http://www.alfalaval.com) to access the information direct.